

INGE

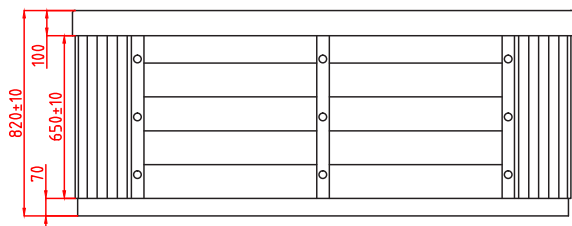
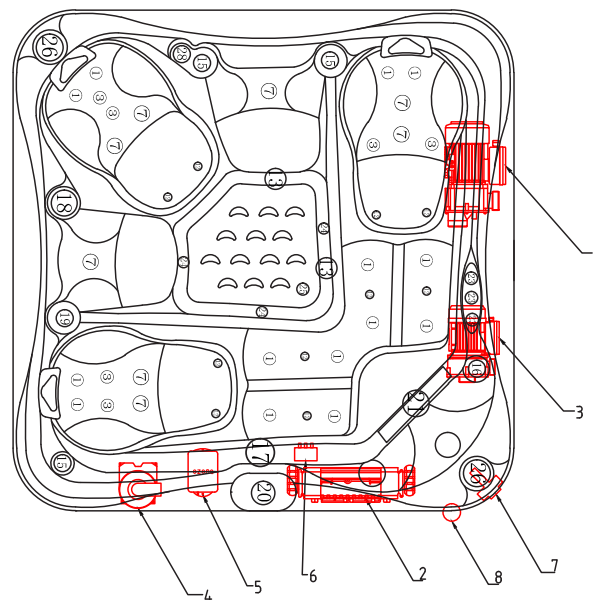
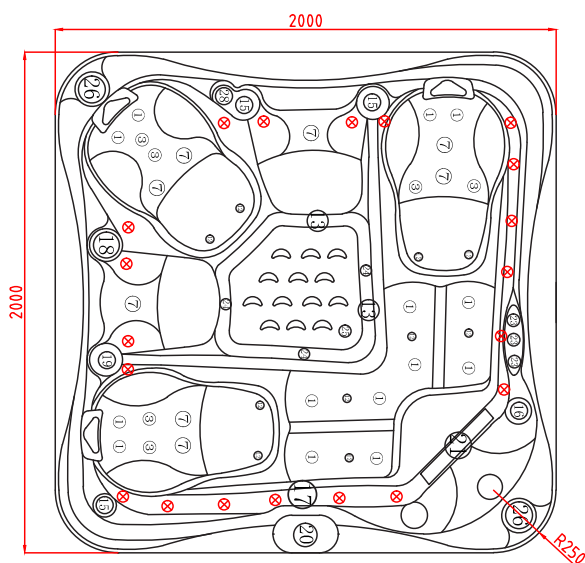

Item	name	number	Item	name	number
1	LX Whirlpool Pump (LP300)	1	2	Balboa BP6013G2 System	1
3	LX Circulate Pump (WTC50)	1	4	Air Blower	1
5	Ozoner Generator	1	6	LED Synchronizer	1
7	Drain	1	8	Cable Hole	1

Item	name	hole size	number	Item	name	hole size	number
1	2" directional jet	∅38	14	3	2.5" directional jet	∅46	6
7	3.5" double roto jet	∅65	8	12	air jet	∅30	10
13	200GPM suction	∅85	2	15	air regulator	∅44	3
16	water controler	∅56	1	17	LED light	∅95	1
18	water diverter	∅80	1	19	aromatherapy	∅44	1
20	TP500S panel	/	1	21	filter	/	1
23	water scape	∅38	3	24	Circulating nozzle	∅30	3
25	drain	∅32	1	26	Pop Up Speaker	/	2
28	Cup stand	∅66	1	⊗	Waterline LED lights	∅12	20